

HX130ALCR

CRAWLER EXCAVATOR



SERIES / HX130ALCR

Gross Power
55 kW (74 HP) at 2200 rpm

Bucket Capacity
0.50 ~ 0.61 m³

Net Power
54 kW (72 HP) at 2200 rpm

Operating Weight
13445 kg

READY TO CHANGE YOUR WORLD

Our new A-Series HX130A LCR crawler excavator is ready to build your world. Its high performance engine delivers better productivity and fuel efficiency while meeting EU Stage V emissions regulations. Featuring a new tough exterior design with added safety features and greater serviceability with no AdBlue needed, the HX130A LCR is the perfect rental machine for performing in the toughest conditions.

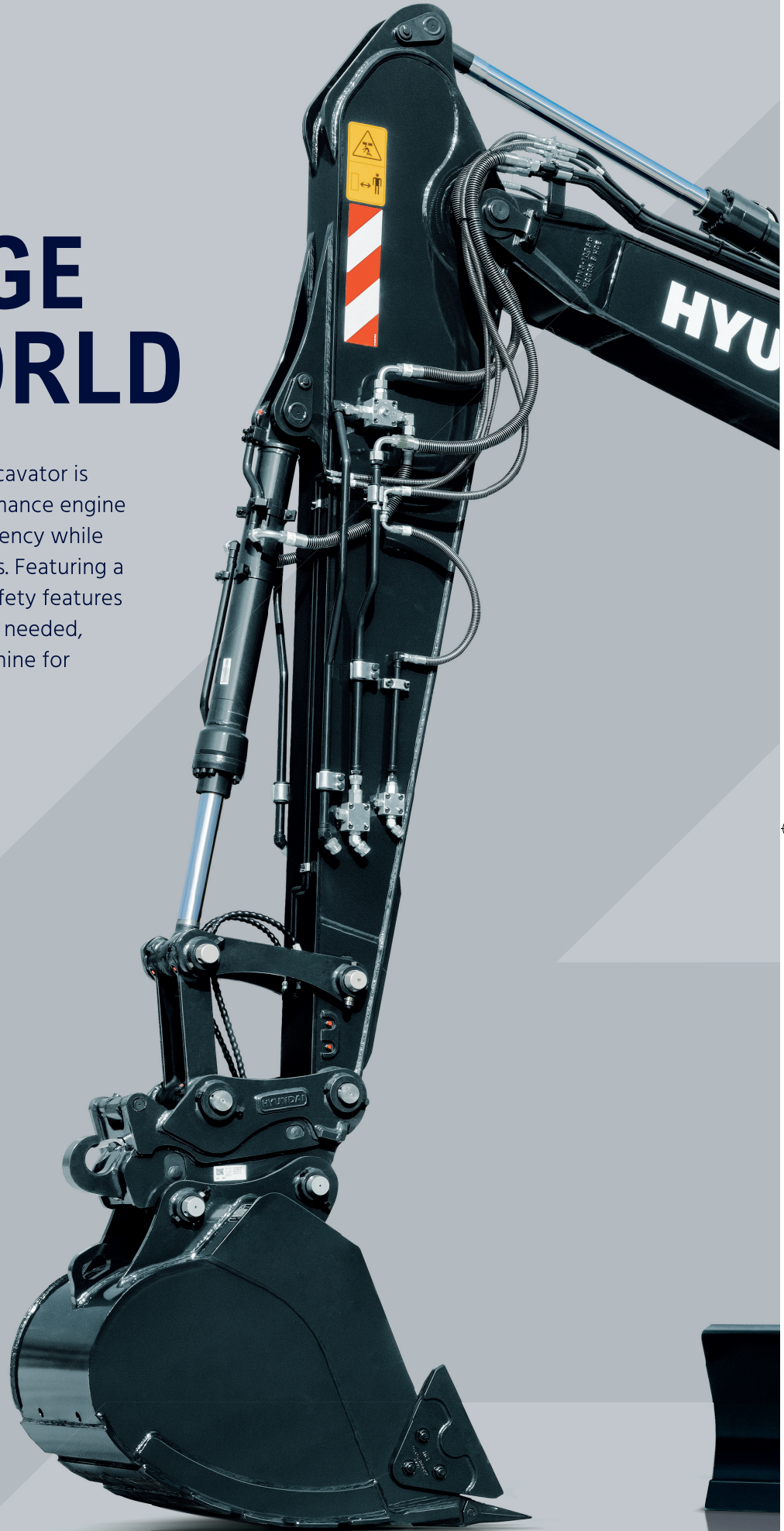

A

SERIES HX130ALCR



THE BEST PRODUCTIVITY AND FUEL EFFICIENCY

From its upgraded, eco-friendly engine to its carefully chosen control technologies, the HX130A LCR excavator helps operators to achieve new heights of productivity. Hyundai's EPIC (Electric Pump Independent Control) hydraulic system, in connection with automatic engine shutdown, eco gauge and lifting mode, allows the machine to deliver the exact performance and efficiency when and where it's needed.

EU Stage V Certified Engine

The HX130A LCR's F3.8 engine features an Adblue/DEF free design, that results in lower running costs.



The Cummins F3.8 engine satisfies the strictest environmental emission regulation in the world including a 60% reduction in Particulate Matter (PM).

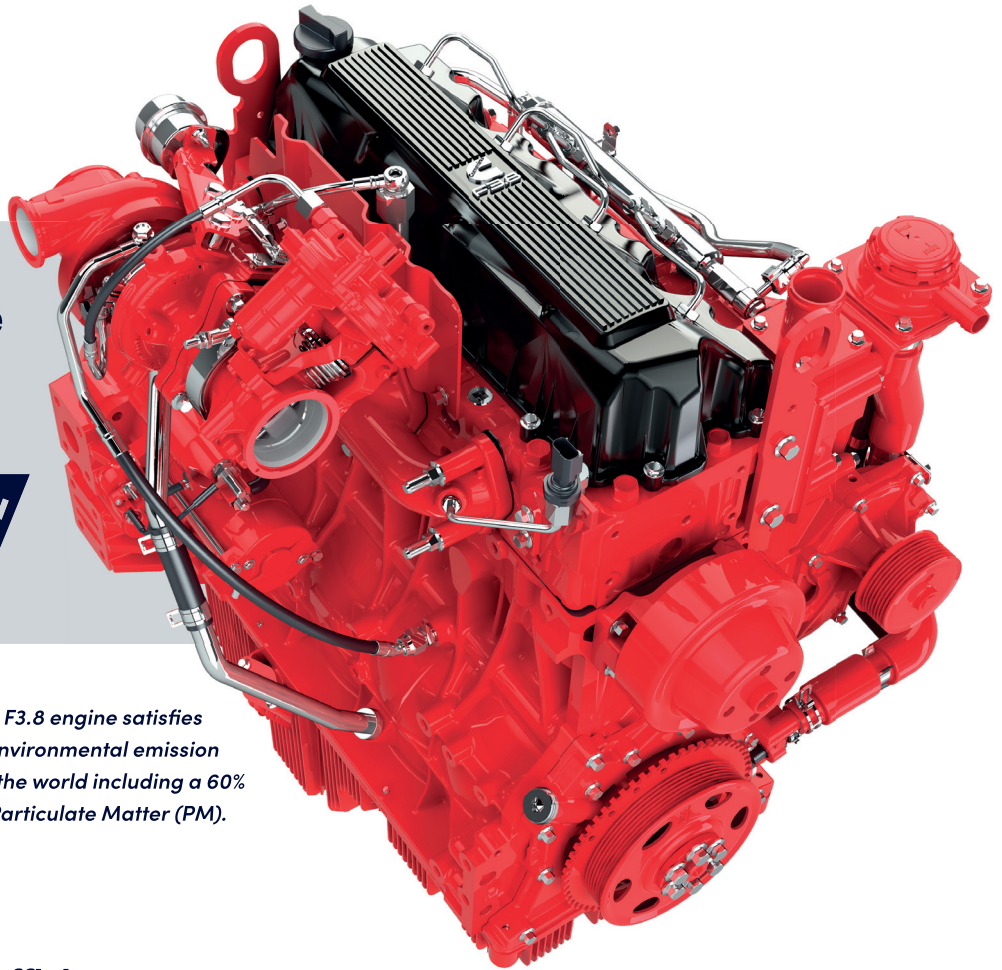

The technology to improve efficiency

EPIC

The HX A-Series adopts the upgraded EPIC system. It is able to optimise pump flow rate and power at various working conditions through the individual pump control. Furthermore, the optimised design of MCV and pipe line minimises energy loss such as conflux and throttle loss.

Lifting mode

This work mode improves fine control and lift capability through RPM reduction, power boost activation and pump flow control.

Automatic Engine Shutdown

Adjustable 'Automatic Engine Shutdown' significantly reduces idle time, overall operating hours and fuel consumption.



Lifting mode



Increased fuel economy and longer maintenance intervals contribute to a reduced cost of operation.

UP TO
19%
EFFICIENCY
(Compared to previous model)

All the information to improve economy

Eco report

It reports on any inefficient operation status and helps improve an operator's working habit.

Fuel rate information

Fuel information is displayed as average rate and latest fuel consumed, for guidance to economical operating.

Eco gauge

Helps operators to reduce emissions and running costs by constantly monitoring efficiency. It displays engine workload and fuel-saving status while the machine is working.



Eco Gauge

NEW EXTERIOR DESIGN FOR ROBUSTNESS AND SAFETY

The true value of the HX A-Series lies in its durability and high productivity. The robust upper and lower frame structure can endure external shock and heavy work loads. Attachment performance has been proven through rigorous field testing. No matter how tough the working environment is, you can always rely on Hyundai A-Series HX excavators.

Tougher from the ground up

Reinforced durability ▶

The upper and lower structure and attachments of HX A-Series machines have higher durability than demanded on site, as proven through numerous tests including on the road and virtual simulation. The wear resistance of the bucket has also been improved by using a new, harder material.

Durable cooling module ▼

The HX A-Series has a durable cooling module that has passed stringent tests, demonstrating the highest productivity in tough working environments.



The robust upper and lower frame structure can endure external shock and heavy work loads.



Cabin structure

The HX A-Series cabin structure uses integrally welded low-stress, high strength steel to meet ROPS and FOG certification.

- **ROPS:** Roll-Over Protective Structures ISO12117-2
- **FOG:** Falling Object Guard, ISO10262 Level2

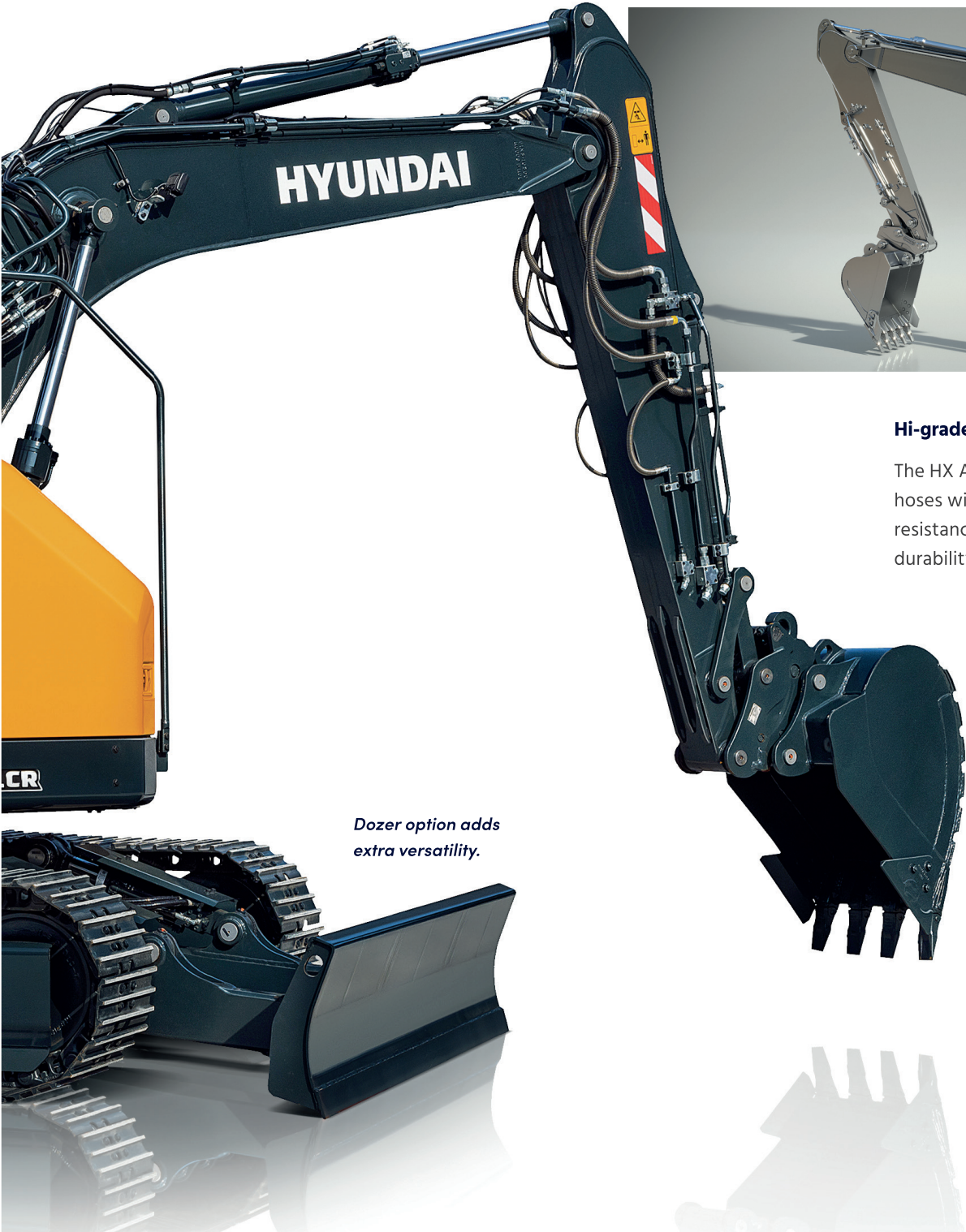

Dozer option adds extra versatility.

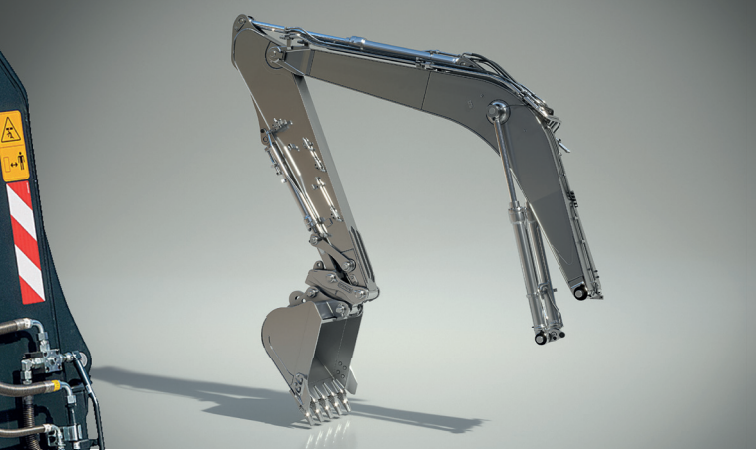

Hi-grade (high-pressure) hoses ▲

The HX A-Series uses high-pressure hoses with improved heat and pressure resistance, greatly increasing the durability of the equipment.

EASY CONTROL AND COMFORTABLE OPERATION

Many electronic functions are concentrated in the most convenient spot for operators to improve work efficiency. The highly-advanced infotainment system, a product of Hyundai's intensive information technology development, enables both productivity and comfort while working! The HX A-Series really is designed with the operator in mind.

Ergonomic for efficient operation

Intelligent & wide cluster ▶

The 8" capacitive-type display is similar to a smartphone to deliver excellent legibility. The centralised switches on the display allow convenient checking and operation of key functions.



One pedal to travel straight ▶

One pedal for straight travel is available for customers' convenience when long distance travelling or a combination of attachment work with travelling is necessary.

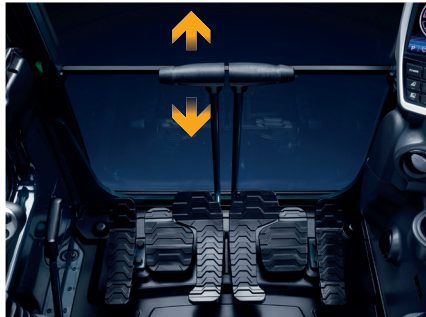

Proportional auxiliary hydraulic system ▶

A proportional control switch with better speed control provides operators with added convenience whenever they do time-consuming work. This function can also be switched to control by foot pedal, by changing the setting in the cluster menu.



Front side vents ▶

Front side vents provide front window demisting and direct clean fresh air to the operator.



Functionality at your fingertips

Boom/Arm speed

Boom-up speed compared to swing speed can be adjusted by activating/deactivating the boom priority function. Arm-in speed can be also tuned by activating/deactivating the arm regeneration function.

Work mode memory

The operator can save machine settings, so that they are applied when starting the machine.

OME (Owner Menu Editing)

The machine owner can restrict operator access to the set of functions via the menu as well as locking or unlocking it. A password is then needed to access the functions.

Fine (cushion/free) swing control

This option enables smooth movement at the start and stop of swing operation (cushion swing). In addition, it reduces the shaking of the weight when lifting operation (free swing).

The HX A-Series is designed with the operator in mind. Many electronic functions are concentrated in the most convenient spot for operators to improve work efficiency.

HYUNDAI

Pilot pressure operated joysticks and pedals with detachable lever provide almost effortless operation.

13%
INCREASE IN CABIN SPACE

THE ULTIMATE SAFE ENVIRONMENT

The Hyundai approach to safety goes far beyond just meeting regulatory standards. We prioritise safety in every aspect of our machines and work with our customers to keep improving protection for operators, co-workers, passers-by, surrounding buildings and of course the machines themselves.

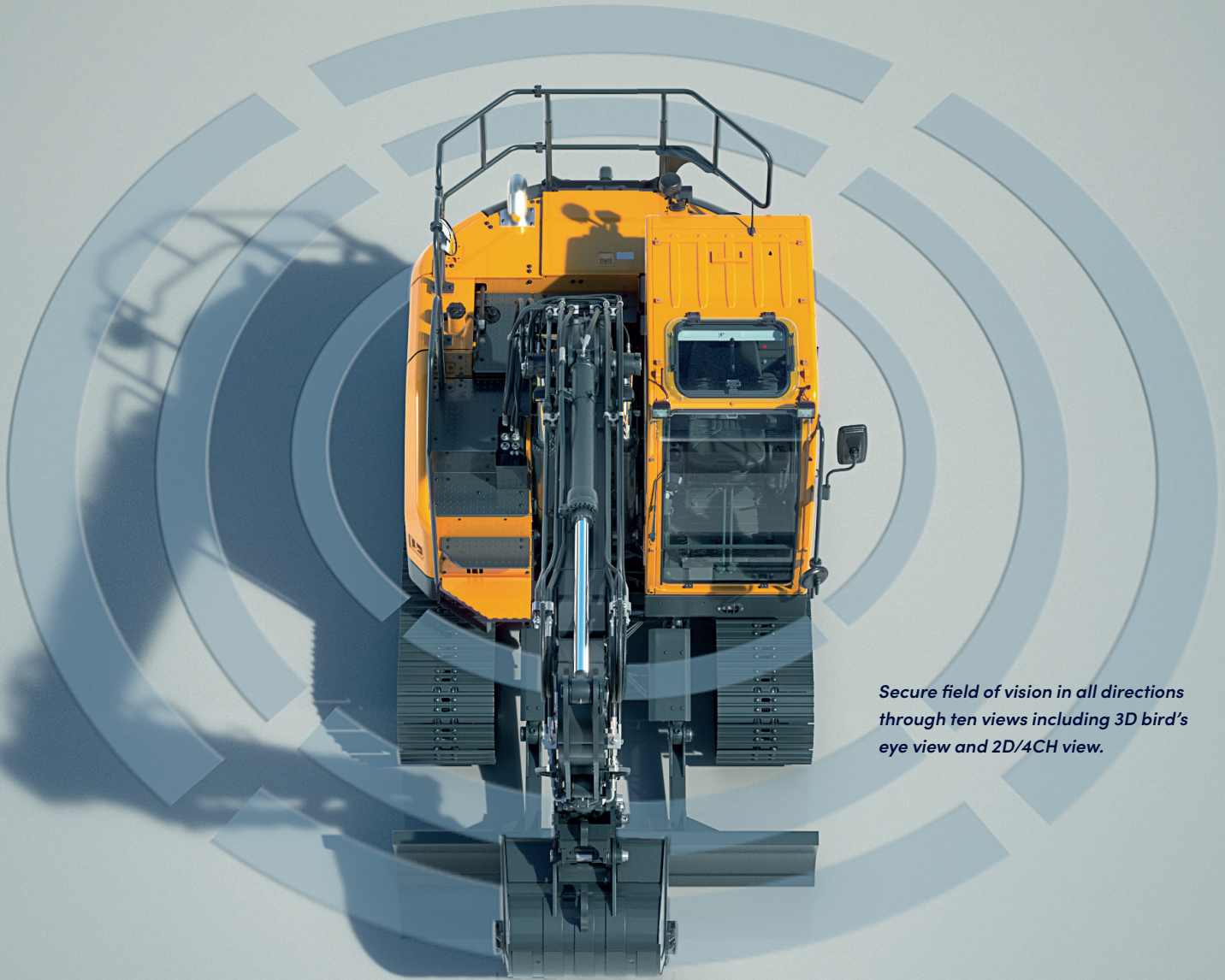

Secure field of vision in all directions through ten views including 3D bird's eye view and 2D/4CH view.

Visibly safer

AAVM (Advanced Around View Monitoring) camera system

The HX A-Series has a state-of-the-art AAVM video camera system to give an unobscured 360 degree field of vision for operators.

- **IMOD (Intelligent Moving Object Detection):** Informs when people or dangerous objects are detected within the range of operation (recognition distance: 5m).



Built for safer operation

Cabin viscous mount

A coil spring and damper inside the cabin viscous mounts improve durability and provide a comfortable operating environment that lessens fatigue.

Emergency engine stop switch

A manual engine stop switch located behind the seat can be used in emergencies. It can also be reached from outside the cabin.

Side camera

In addition to the standard rear view camera, there is an optional right hand side camera for giving the operator improved visibility.

Seat belt warning alarm

If the seat belt is not buckled when the ignition key is turned, an alarm is triggered in intervals along with a continuous visual alert. This emphasises our priority for operator safety.

Electronic swing brake

An electronic valve and control system has been added to improve safety and utilisation. The opening and closing time of the swing brake valve is controlled according to the sensing and control system.

Visibility and handle improvement ▶

Visibility through the cabin door has been improved as has the handle design, to offer greater convenience when getting in and out of the cabin.



Activate Auto Safety Check

The Auto Safety Lock prevents unintended operation due to the excavator not being controlled solely by the RCV lever.



RCV lever is pressed



Unlock safety lever

Turn on indicator



Activate "auto safety lock"



Excavator is not controlled by RCV lever and prevents unintended operation

SERVICEABILITY AND TELEMATICS

Our A-Series excavators are designed with quick, low-effort servicing in mind. Every component and material has been optimised to ensure a long, trouble-free life. Hyundai's innovative Hi MATE telematics system enables full monitoring of machine activity and performance. Maximum connectivity is integrated to help owners create a smart construction site and protect profitability as their business grows.

Less maintenance. More uptime

Improved routine maintenance

Easy access for maintenance means regular checks get done faster, giving you more uptime and reducing operating costs. Ground level access to filters, lube fittings and master switches make servicing more convenient.

2 x longer lasting filter (1000 hr)

Service intervals have increased by 100% from 500hrs to 1000hrs when using CK-4 engine oil on the following items, engine oil, pre-filter, engine oil filter and fuel filter.

100%
IMPROVEMENT IN
SERVICE INTERVAL



Hi MATE

It's convenient, easy and valuable. Hi MATE, Hyundai's remote management system, utilises GPS-satellite technology to provide customers with the highest level of service and product support available.

Increase productivity

By providing information such as service hours, idle time and fuel consumption, Hi MATE saves you money and improves productivity. Service alerts enable better maintenance planning.

Monitor your machines

Hi MATE's real-time location information allows convenient monitoring of your equipment via the Hi MATE website or mobile app.

Improve Security

Protect your equipment from theft or unauthorised usage. Hi MATE's geofencing alerts notify you automatically when a machine leaves a predetermined zone.

ECD

(Engine Connected Diagnostics)

ECD provides troubleshooting information as well as tailored servicing. Service technicians are supported with remote diagnostics allowing them to achieve quick resolution rate

Mobile fleet app

Our Mobile Fleet app provides all the information you need to run your fleet efficiently and economically.



HCE-DT Air connects you and your equipment wirelessly via smartphone and laptop right on site.

Keeping you covered

Hyundai genuine parts and accessories are designed to keep your machine running at optimum performance, providing increased uptime, comfort and productivity. Our 13000m² European Parts Warehouse guarantees 24-hour delivery across our dealer network.

Hyundai Standard and Extended Warranty Programmes are also available, providing peace of mind and giving you full control over your operating costs.



TAKE THE TOUR!

Productivity & Efficiency

- EU STAGE V Engine
- Eco Report
- Lifting Mode
- EPIC
- Fuel Rate Information
- Eco Gauge
- Automatic Engine Shutdown

Ease of Use

- Work mode memory
- Visibility and handle improvement
- One pedal straight travel
- Proportional auxiliary hydraulic system
- 2 way proportional RCV & pedal control selection
- Fine (cushion/free) swing control
- Intelligent & wide cluster
- OME (Owner Menu Editing)
- Boom / arm speed adjustment

Durability

- Frame side protection
- ROPS & FOG cabin
- Reinforced durability
- Durable cooling module
- High-grade hoses

Safety

- Auto safety lock
- Electronic swing brake
- AAVM camera system
- Side view camera
- Seatbelt warning alarm
- Emergency engine stop switch

Serviceability & Connectivity

- Hi MATE
 - ECD (Engine Connected Diagnostics)
 - Mobile fleet app
- HCE-DT Air
- Longer lasting filter
- Improved routine maintenance



4

SERIES HX130ALCR



SPECIFICATIONS

SPECIFICATIONS		HX130A LCR
ENGINE		
Maker / Model	Cummins F3.8	
Type	4-cycle, turbocharged, charge air cooled, electronic controlled diesel engine	
Gross Power (SAE J1995)	55 kW (74 HP) at 2200 rpm	
Net Power (SAE J1349)	54 kW (72 HP) at 2200 rpm	
Max. Power	55 kW (74 HP) at 2200 rpm	
Peak Torque	400 N·m (295 lb·ft) at 1300 rpm	
Displacement	3.8 l	
HYDRAULIC SYSTEM		
MAIN PUMP		
Type	Variable displacement tandem axis piston pumps	
Max. flow	2 × 117 l/min	
PILOT PUMP		
Type	Fixed displacement gear pump single stage	
Max. flow	27 l/min	
HYDRAULIC MOTORS		
Travel	Variable displacement axial piston motor	
Swing	Two fixed displacement axial piston motor	
RELIEF VALVE SETTING		
Implement Circuits	330 kgf/cm ²	
Travel	350 kgf/cm ²	
Power Boost (Boom, Arm, Bucket)	380 kgf/cm ²	
Swing Circuit	280 kgf/cm ²	
Pilot Circuit	40 kgf/cm ²	
HYDRAULIC CYLINDERS		
No. of Cylinder Bore X Stroke	Boom: 2-Ø100 × 1015 mm	
	Arm: 1-Ø110 × 1070 mm	
	Bucket: 1-Ø100 × 855 mm	
	Blade: 2-Ø100 × 240 mm	
	2PCS	1st: 2-Ø100 × 975 mm 2nd: 1-Ø145 × 613 mm
*Hyundai Bio Hydraulic Oil (HBHO) available.		
DRIVES & BRAKES		
Drive Method	Fully hydrostatic type	
Drive Motor	Axial piston motor, in-shoe design	
Reduction System	Planetary reduction gear	
Max. Drawbar Pull	11948 kgf	
Max. Travel Speed (High / Low)	3.0 km/hr / 5.2 km/hr	
Gradeability	35° (70%)	
Parking Brake	Multi wet disc	
CONTROLS		
Pilot Control	Two joysticks with one safety lever	
	(LH): Swing and arm (RH): Boom and bucket	
Traveling and Steering	Two levers with pedals	
Engine Throttle	Electric, dial type	
SWING SYSTEM		
Swing Motor	Two fixed displacement axial piston motor	
Swing Reduction	2-stage planetary	
Swing Bearing Lubrication	Grease-bathed	
Swing Brake	Multi wet disc	
Swing Speed	12.4 rpm	

SPECIFICATIONS		HX130A LCR		
COOLANT & LUBRICANT CAPACITY				
		liter		
Fuel Tank		240		
Engine Coolant		24.5		
Engine Oil		12		
Swing Device		3.5		
Final Drive		2.3		
Hydraulic System (Including Tank)		160		
Hydraulic Tank		96		
UNDERCARRIAGE				
The X-leg type center frame is integrally welded with reinforced box-section track frames. The undercarriage includes lubricated rollers, idlers, track adjusters with shock absorbing springs and sprockets, and a track chain with double or triple grouser shoes.				
Center Frame		X - Leg Type		
Track Frame		Pentagonal Box Type		
No. of Shoes on Each Side		43 EA		
No. of Carrier Roller		2 x 1 EA		
No. of Track Roller		2 x 6 EA		
No. of Rail Guard		2 EA		
OPERATING WEIGHT				
Operating weight, including 4,300 mm boom, 2,260 mm arm, SAE heaped 0.58 m ³ bucket, lubricant, coolant, full fuel tank, full hydraulic tank, and all standard equipments.				
OPERATING WEIGHT				
Shoes		Operating Weight		Ground Pressure
Type	Width (mm)	kg	kgf / cm ²	
Triple Grouser	500	HX130A LCR	13265	0.44
		HX130A LCR (Rubber pad)	13420	0.44
		HX130A LCRD	14090	0.47
		HX130A LCRD (Rubber pad)	14240	0.46
	600	HX130A LCR	13445	0.37
		HX130A LCR (HD grouser)	13770	0.38
		HX130A LCRD	14275	0.39
		HX130A LCR (HD grouser)	14600	0.40
	700	HX130A LCR	13605	0.32
		HX130A LCR (HD grouser)	13970	0.33
		HX130A LCRD	14445	0.34
		HX130A LCR (HD grouser)	14810	0.35
NOISE				
Operator Sound Pressure Level (ISO 6396:2008)			72 dB(A)	
Exterior Sound Power Level (ISO 6395:2008)			99 dB(A)	
AIR CONDITIONING SYSTEM				
The air condition system for the machine contains the fluorinated greenhouse gas with global warming potential of R134a. (Global Warming Potential : 1,430) The system hold 0.65 kg refrigerant consisting of a CO ₂ equivalent of 0.93 metric tonnes. For more information, Please refer to the manual.				

DIMENSIONS & WORKING RANGE

HX130A LCR MONO BOOM

4.30 m BOOM and 1.96 m, 2.26 m, 2.81 m ARM

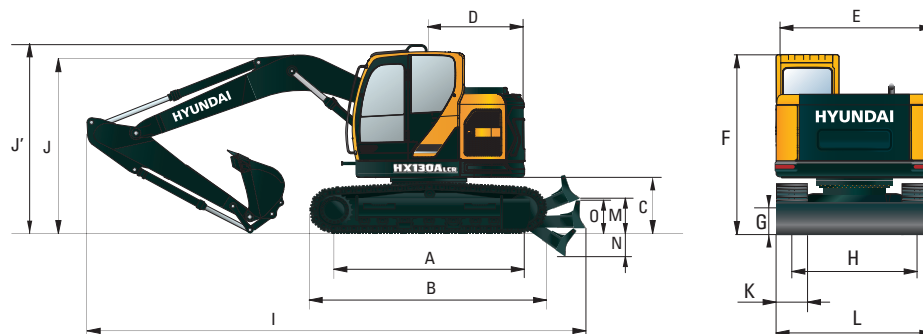

Unit : mm

A	Tumbler Distance	2780
B	Overall Length of Crawler	3497
C	Ground Clearance of Counter Weight	900
D	Tail Swing Radius	1520
D'	Rear-End Length	1520
E	Overall Width of Upper Structure	2485
F	Overall Height of Cab	2860
G	Min. Ground Clearance	435
H	Track gauge	1990
J'	Overall Height of Guardrail	3080

	Boom length	4300		
	Arm length	1960	2260	2810
I	Overall Length	6820	6850	6805
**I	Overall Length	7585	7615	7570
*J	Overall Height of Boom	2570	2760	3080

K	Track Shoe Width	500	600	700
L	Overall Width	2490	2590	2690

**M	Ground clearance of blade up	550
**N	Depth of blade down	515
**O	Height of blade	575

* This figure includes the size of grouser.

** With dozer blade option.

HX130A LCR WORKING RANGE

Unit : mm

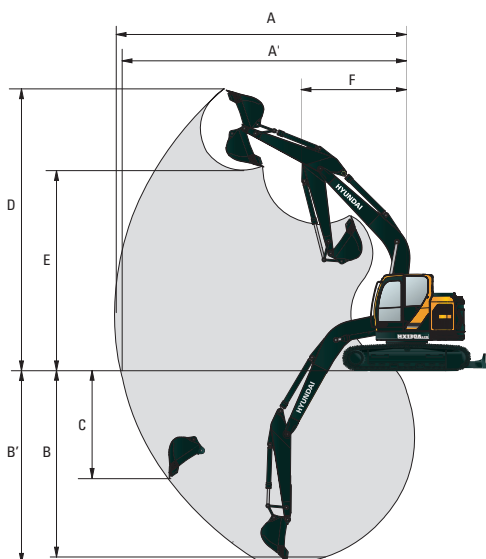

Boom Length		4300		
Arm Length		1960	2260	2810
A	Max. Digging Reach	7470	7745	8270
A'	Max. Digging Reach on Ground	7310	7600	8140
B	Max. Digging Depth	4790	5090	5640
B'	Max. Digging Depth (8' Level)	4530	4860	5450
C	Max. Vertical Wall Digging Depth	4330	4630	5170
D	Max. Digging Height	7975	8165	8540
E	Max. Dumping Height	5530	5710	6090
F	Min. Swing Radius	2275	2340	2470

DIMENSIONS & WORKING RANGE

HX130A LCR 2-PIECE BOOM DIMENSIONS

4.56 m 2-Piece BOOM and 1.96 m, 2.26 m ARM

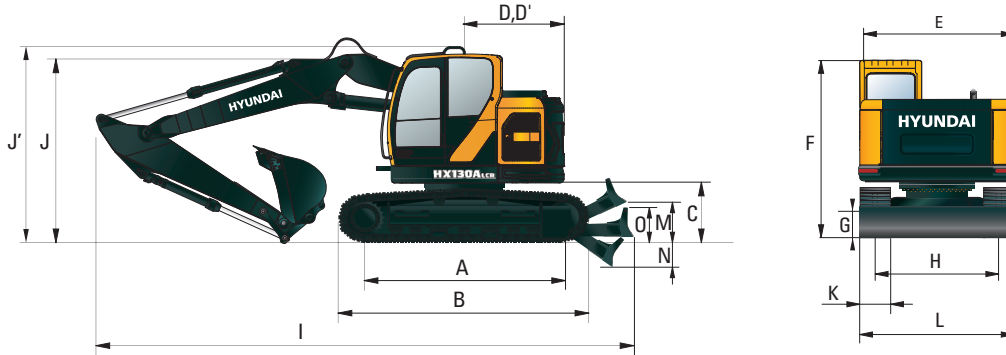

Unit : mm

A	Tumbler Distance	2780
B	Overall Length of Crawler	3497
C	Ground Clearance of Counter Weight	900
D	Tail Swing Radius	1520
D'	Rear-End Length	1520
E	Overall Width of Upper Structure	2485
F	Overall Height of Cab	2860
G	Min. Ground Clearance	435
H	Track gauge	1990
J'	Overall Height of Guardrail	3080

	Boom length	4560		
	Arm length	1960	2260	
I	Overall Length	7100	7090	
**I	Overall Length	7865	7855	
*J	Overall Height of Boom	2835	3000	

K	Track shoe width	500	600	700
L	Overall Width	2490	2590	2690

**M	Ground clearance of blade up	550
**N	Depth of blade down	515
**O	Height of blade	575

* This figure includes the size of grouser.

** With dozer blade option.

HX130A LCR / HX130A LCRD 2-PIECE BOOM WORKING RANGE

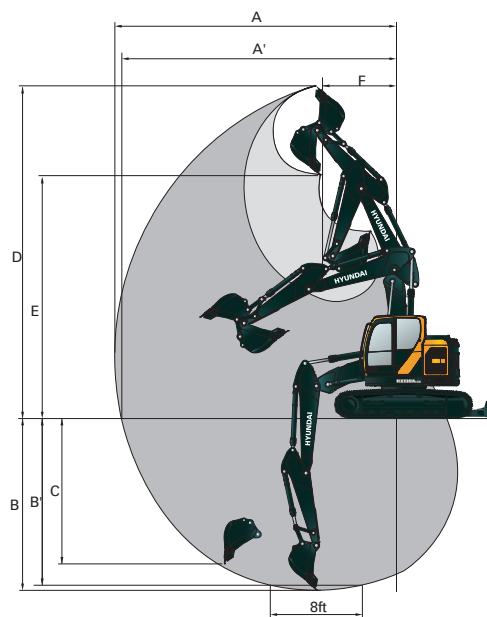

Unit : mm











Boom Length	4560			
Arm Length	1960	2260		
A	Max. Digging Reach	7770	8060	
A'	Max. Digging Reach on Ground	7630	7920	
B	Max. Digging Depth	4980	5280	
B'	Max. Digging Depth (8' Level)	4860	5160	
C	Max. Vertical Wall Digging Depth	4370	4680	
D	Max. Digging Height	8650	8880	
E	Max. Dumping Height	6160	6390	
F	Min. Swing Radius	2220	2430	

LIFTING CAPACITY











 Rating over-front  Rating over-side or 360 degrees

HX130A LCR MONO BOOM











4.30 m boom, 1.96 m arm equipped with 2100kg counter weight and 600mm triple grouser shoe without Dozer.

Lift-point height m	Lift-point radius								At max. Reach			
	1.5 m		3.0 m		4.5 m		6.0 m		Capacity		Reach m	
												
6.0 m	kg									*2620	*2620	4.21
4.5 m	kg					*3340	3060			*2310	2240	5.42
3.0 m	kg			*5290	*5290	*3920	2930	*2450	1860	*2270	1850	6.03
1.5 m	kg			*7380	5000	4080	2760	2630	1810	*2390	1720	6.22
0.0 m	kg			*7210	4820	3950	2650	2590	1780	2570	1760	6.04
-1.5 m	kg	*5310	*5310	7800	4820	3930	2620			2980	2030	5.44
-3.0 m	kg			*6500	4950					*4350	2940	4.26

4.30 m boom, 1.96 m arm equipped with 2100kg counter weight and 600mm triple grouser shoe with Dozer Up

Lift-point height m	Lift-point radius								At max. Reach			
	1.5 m		3.0 m		4.5 m		6.0 m		Capacity		Reach m	
												
6.0 m	kg									*2620	*2620	4.21
4.5 m	kg					*3350	3240			*2310	*2310	5.42
3.0 m	kg			*5290	*5290	*3930	3110	*2460	1990	*2270	1980	6.03
1.5 m	kg			*7360	5320	4040	2940	2610	1940	*2390	1840	6.22
0.0 m	kg			*7220	5140	3910	2830	2570	1900	2540	1890	6.04
-1.5 m	kg	*5320	*5320	7720	5150	3890	2810			2950	2180	5.44
-3.0 m	kg			*6500	5280					*4350	3140	4.26

4.30 m boom, 1.96 m arm equipped with 2100kg counter weight and 600mm triple grouser shoe with Dozer Down.

Lift-point height m	Lift-point radius								At max. Reach			
	1.5 m		3.0 m		4.5 m		6.0 m		Capacity		Reach m	
												
6.0 m	kg									*2620	*2620	4.21
4.5 m	kg					*3350	*3350			*2310	*2310	5.42
3.0 m	kg			*5290	*5290	*3930	3370	*2460	2150	*2270	2140	6.03
1.5 m	kg			*7360	5870	*4730	3200	*3780	2100	*2390	1990	6.22
0.0 m	kg			*7220	5680	*5280	3080	*3100	2060	*2730	2050	6.04
-1.5 m	kg	*5320	*5320	*7920	5690	*5260	3060			*3490	2360	5.44
-3.0 m	kg			*6500	5820					*4350	3420	4.26











1. Lifting capacities are based on ISO 10567.
2. Lifting capacity of the HX A-series does not exceed 75% of tipping load with the machine on firm, level ground or 87% of full hydraulic capacity.
3. The Lift-point is bucket pivot mounting pin on the arm (without bucket mass).
4. (*) indicates load limited by hydraulic capacity.
5. Caution: please be aware of the local regulations and instructions for lifting operations.

LIFTING CAPACITY











 Rating over-front  Rating over-side or 360 degrees

HX130A LCR MONO BOOM











4.30 m boom, 196 m arm equipped with 2450kg counter weight and 600mm triple grouser shoe without Dozer.

Lift-point height m	Lift-point radius								At max. Reach			
	1.5 m		3.0 m		4.5 m		6.0 m		Capacity		Reach m	
												
6.0 m	kg									*2620	*2620	4.21
4.5 m	kg					*3340	3240			*2310	*2310	5.42
3.0 m	kg			*5290	*5290	*3920	3110	*2450	1990	*2270	1980	6.03
1.5 m	kg			*7380	5320	4300	2940	2790	1940	*2390	1840	6.22
0.0 m	kg			*7210	5140	4180	2830	2750	1900	2720	1880	6.04
-1.5 m	kg	*5310	*5310	*7920	5140	4150	2800			3160	2170	5.44
-3.0 m	kg			*6500	5270					*4350	3130	4.26

4.30 m boom, 196 m arm equipped with 2450kg counter weight and 600mm triple grouser shoe with Dozer Up.

Lift-point height m	Lift-point radius								At max. Reach			
	1.5 m		3.0 m		4.5 m		6.0 m		Capacity		Reach m	
												
6.0 m	kg									*2620	*2620	4.21
4.5 m	kg					*3350	*3350			*2310	*2310	5.42
3.0 m	kg			*5290	*5290	*3930	3290	*2460	2120	*2270	2100	6.03
1.5 m	kg			*7360	5640	4260	3120	2760	2070	*2390	1960	6.22
0.0 m	kg			*7220	5460	4140	3010	2720	2030	2700	2010	6.04
-1.5 m	kg	*5320	*5320	*7920	5470	4110	2990			3130	2320	5.44
-3.0 m	kg			*6500	5600					*4350	3330	4.26

4.30 m boom, 196 m arm equipped with 2450kg counter weight and 600mm triple grouser shoe with Dozer Down.











Lift-point height m	Lift-point radius								At max. Reach			
	1.5 m		3.0 m		4.5 m		6.0 m		Capacity		Reach m	
												
6.0 m	kg									*2620	*2620	4.21
4.5 m	kg					*3350	*3350			*2310	*2310	5.42
3.0 m	kg			*5290	*5290	*3930	3560	*2460	2280	*2270	*2270	6.03
1.5 m	kg			*7360	6210	*4730	3390	*3780	2230	*2390	2120	6.22
0.0 m	kg			*7220	6020	*5280	3270	*3100	2190	*2730	2180	6.04
-1.5 m	kg	*5320	*5320	*7920	6030	*5260	3250			*3490	2510	5.44
-3.0 m	kg			*6500	6160					*4350	3620	4.26

1. Lifting capacities are based on ISO 10567.
2. Lifting capacity of the HX A-series does not exceed 75% of tipping load with the machine on firm, level ground or 87% of full hydraulic capacity.
3. The Lift-point is bucket pivot mounting pin on the arm (without bucket mass).
4. (*) indicates load limited by hydraulic capacity.
5. Caution: please be aware of the local regulations and instructions for lifting operations.











 Rating over-front
  Rating over-side or 360 degrees

HX130A LCR MONO BOOM











4.30 m boom, 2.26 m arm equipped with 2100kg counter weight and 600mm triple grouser shoe without Dozer.

Lift-point height m	Lift-point radius								At max. Reach			
	1.5 m		3.0 m		4.5 m		6.0 m		Capacity		Reach m	
												
6.0 m	kg					*2730	*2730			*2360	*2360	4.62
4.5 m	kg					*3070	*3070			*2110	2050	5.74
3.0 m	kg			*4770	*4770	*3690	2950	2700	1880	*2070	1720	6.31
1.5 m	kg			*7100	5060	4090	2770	2630	1810	*2180	1600	6.5
0.0 m	kg			*7500	4810	3950	2640	2580	1760	2390	1640	6.32
-1.5 m	kg	*4830	*4830	7750	4780	3900	2800			2730	1860	5.76
-3.0 m	kg	*9240	*9240	*6920	4890	3970	2670			3780	2550	4.66

4.30 m boom, 2.26 m arm equipped with 2100kg counter weight and 600mm triple grouser shoe with Dozer Up.

Lift-point height m	Lift-point radius								At max. Reach			
	1.5 m		3.0 m		4.5 m		6.0 m		Capacity		Reach m	
												
6.0 m	kg					*2740	*2740			*2350	*2350	4.62
4.5 m	kg					*3070	*3070			*2110	*2110	5.74
3.0 m	kg			*4780	*4780	*3690	3130	2680	2000	*2070	1840	6.31
1.5 m	kg			*7110	5380	4050	2950	2610	1940	*2180	1720	6.5
0.0 m	kg			*7510	5130	3910	2820	2550	1890	2370	1750	6.32
-1.5 m	kg	*4840	*4840	7670	5110	3860	2780			2700	1990	5.76
-3.0 m	kg	*9260	*9260	*6910	5210	3940	2850			3750	2720	4.66

4.30 m boom, 2.26 m arm equipped with 2100kg counter weight and 600mm triple grouser shoe with Dozer Down.

Lift-point height m	Lift-point radius								At max. Reach			
	1.5 m		3.0 m		4.5 m		6.0 m		Capacity		Reach m	
												
6.0 m	kg					*2740	*2740			*2350	*2350	4.62
4.5 m	kg					*3070	*3070			*2110	*2110	5.74
3.0 m	kg			*4780	*4780	*3690	3390	*3300	2170	*2070	1990	6.31
1.5 m	kg			*7110	5930	*4540	3210	*3650	2100	*2180	1860	6.5
0.0 m	kg			*7510	5670	*5180	3080	*3900	2050	*2460	1910	6.32
-1.5 m	kg	*4840	*4840	*8060	5640	*5300	3030			*3070	2160	5.76
-3.0 m	kg	*9260	*9260	*6910	5750	*4440	3100			*4180	2960	4.66











1. Lifting capacities are based on ISO 10567.
2. Lifting capacity of the HX A-series does not exceed 75% of tipping load with the machine on firm, level ground or 87% of full hydraulic capacity.
3. The Lift-point is bucket pivot mounting pin on the arm (without bucket mass).
4. (*) indicates load limited by hydraulic capacity.
5. Caution: please be aware of the local regulations and instructions for lifting operations.

LIFTING CAPACITY











 Rating over-front  Rating over-side or 360 degrees

HX130A LCR MONO BOOM











4.30 m boom, 2.26 m arm equipped with 2450kg counter weight and 600mm triple grouser shoe without Dozer.

Lift-point height m	Lift-point radius								At max. Reach			
	1.5 m		3.0 m		4.5 m		6.0 m		Capacity	Reach		
											m	
6.0 m	kg					*2730	*2730			*2360	*2360	4.62
4.5 m	kg					*3070	*3070			*2110	*2110	5.74
3.0 m	kg			*4770	*4770	*3690	3130	2860	2000	*2070	1840	6.31
1.5 m	kg			*7100	5380	4320	2950	2790	1940	*2180	1720	6.5
0.0 m	kg			*7500	5130	4170	2820	2730	1890	*2460	1750	6.32
-1.5 m	kg	*4830	*4830	*8060	5100	4130	2780			2890	1990	5.76
-3.0 m	kg	*9240	*9240	*6920	5200	4200	2850			3990	2720	4.66

4.30 m boom, 2.26 m arm equipped with 2450kg counter weight and 600mm triple grouser shoe with Dozer Up.

Lift-point height m	Lift-point radius								At max. Reach			
	1.5 m		3.0 m		4.5 m		6.0 m		Capacity	Reach		
											m	
6.0 m	kg					*2740	*2740			*2350	*2350	4.62
4.5 m	kg					*3070	*3070			*2110	*2110	5.74
3.0 m	kg			*4780	*4780	*3690	3310	2830	2130	*2070	1960	6.31
1.5 m	kg			*7110	5700	4280	3130	2760	2070	*2180	1830	6.5
0.0 m	kg			*7510	5450	4130	3000	2700	2010	*2460	1870	6.32
-1.5 m	kg	*4840	*4840	*8060	5420	4090	2960			2860	2120	5.76
-3.0 m	kg	*9260	*9260	*6910	5530	4160	3030			3960	2900	4.66

4.30 m boom, 2.26 m arm equipped with 2450kg counter weight and 600mm triple grouser shoe with Dozer Down.











Lift-point height m	Lift-point radius								At max. Reach			
	1.5 m		3.0 m		4.5 m		6.0 m		Capacity	Reach		
											m	
6.0 m	kg					*2740	*2740			*2350	*2350	4.62
4.5 m	kg					*3070	*3070			*2110	*2110	5.74
3.0 m	kg			*4780	*4780	*3690	3580	*3300	2300	*2070	*2070	6.31
1.5 m	kg			*7110	6270	*4540	3400	*3650	2230	*2180	1980	6.5
0.0 m	kg			*7510	6010	*5180	3260	*3900	2180	*2460	2030	6.32
-1.5 m	kg	*4840	*4840	*8060	5980	*5300	3220			*3070	2300	5.76
-3.0 m	kg	*9260	*9260	*6910	6090	*4440	3290			*4180	3140	4.66

1. Lifting capacities are based on ISO 10567.
2. Lifting capacity of the HX A-series does not exceed 75% of tipping load with the machine on firm, level ground or 87% of full hydraulic capacity.
3. The Lift-point is bucket pivot mounting pin on the arm (without bucket mass).
4. (*) indicates load limited by hydraulic capacity.
5. Caution: please be aware of the local regulations and instructions for lifting operations.











 Rating over-front  Rating over-side or 360 degrees

HX130A LCR MONO BOOM











4.30 m boom, 2.81 m arm equipped with 2100kg counter weight and 600mm triple grouser shoe without Dozer.

Lift-point height m	Lift-point radius								At max. Reach			
	1.5 m		3.0 m		4.5 m		6.0 m		Capacity		Reach m	
												
6.0 m	kg					*2480	*2480			*1770	*1770	5.34
4.5 m	kg					*2560	*2560	*2380	1940	*1610	*1610	6.33
3.0 m	kg			*3790	*3790	*3210	3000	2720	1890	*1590	1500	6.86
1.5 m	kg			*6250	5190	4120	2800	2630	1810	*1660	1410	7.03
0.0 m	kg			7800	4820	3940	2630	2560	1740	*1840	1420	6.87
-1.5 m	kg	*4140	*4140	7680	4720	3860	2560	2520	1710	*2220	1580	6.35
-3.0 m	kg	*7280	*7280	*7470	4770	3880	2580			2990	2020	5.38

4.30 m boom, 2.81 m arm equipped with 2100kg counter weight and 600mm triple grouser shoe with Dozer Up.

Lift-point height m	Lift-point radius								At max. Reach			
	1.5 m		3.0 m		4.5 m		6.0 m		Capacity		Reach m	
												
6.0 m	kg					*2480	*2480			*1770	*1770	5.34
4.5 m	kg					*2560	*2560	*2380	2060	*1610	*1610	6.33
3.0 m	kg			*3800	*3800	*3220	3180	2690	2020	*1590	*1590	6.86
1.5 m	kg			*6260	5510	4080	2980	2610	1940	*1660	1510	7.03
0.0 m	kg			7730	5140	3900	2810	2530	1860	*1840	1530	6.87
-1.5 m	kg	*4140	*4140	7600	5040	3820	2740	2500	1830	*2220	1700	6.35
-3.0 m	kg	*7290	*7290	*7460	5100	3840	2760			2970	2170	5.38

4.30 m boom, 2.81 m arm equipped with 2100kg counter weight and 600mm triple grouser shoe with Dozer Down.

Lift-point height m	Lift-point radius								At max. Reach			
	1.5 m		3.0 m		4.5 m		6.0 m		Capacity		Reach m	
												
6.0 m	kg					*2480	*2480			*1770	*1770	5.34
4.5 m	kg					*2560	*2560	*2380	2230	*1610	*1610	6.33
3.0 m	kg			*3800	*3800	*3220	*3220	*2990	2180	*1590	*1590	6.86
1.5 m	kg			*6260	6070	*4150	3230	*3390	2100	*1660	1640	7.03
0.0 m	kg			*7840	5680	*4940	3070	*3750	2030	*1840	1670	6.87
-1.5 m	kg	*4140	*4140	*8160	5580	*5280	2990	*3840	2000	*2220	1850	6.35
-3.0 m	kg	*7290	*7290	*7460	5630	*4910	3010			*3130	2360	5.38











1. Lifting capacities are based on ISO 10567.
2. Lifting capacity of the HX A-series does not exceed 75% of tipping load with the machine on firm, level ground or 87% of full hydraulic capacity.
3. The Lift-point is bucket pivot mounting pin on the arm (without bucket mass).
4. (*) indicates load limited by hydraulic capacity.
5. Caution: please be aware of the local regulations and instructions for lifting operations.

LIFTING CAPACITY











 Rating over-front  Rating over-side or 360 degrees

HX130A LCR MONO BOOM











4.30 m boom, 2.81 m arm equipped with 2450kg counter weight and 600mm triple grouser shoe without Dozer.

Lift-point height m	Lift-point radius								At max. Reach			
	1.5 m		3.0 m		4.5 m		6.0 m		Capacity		Reach m	
												
6.0 m	kg					*2480	*2480			*1770	*1770	5.34
4.5 m	kg					*2560	*2560	*2380	2060	*1610	*1610	6.33
3.0 m	kg			*3790	*3790	*3210	3180	2870	2020	*1590	*1590	6.86
1.5 m	kg			*6250	5510	*4150	2980	2790	1930	*1660	1510	7.03
0.0 m	kg			*7830	5140	4170	2810	2710	1860	*1840	1530	6.87
-1.5 m	kg	*4140	*4140	8120	5030	4080	2730	2680	1830	*2220	1700	6.35
-3.0 m	kg	*7280	*7280	*7470	5090	4110	2750			*3120	2170	5.38

4.30 m boom, 2.81 m arm equipped with 2450kg counter weight and 600mm triple grouser shoe with Dozer Up.

Lift-point height m	Lift-point radius								At max. Reach			
	1.5 m		3.0 m		4.5 m		6.0 m		Capacity		Reach m	
												
6.0 m	kg					*2480	*2480			*1770	*1770	5.34
4.5 m	kg					*2560	*2560	*2380	2190	*1610	*1610	6.33
3.0 m	kg			*3800	*3800	*3220	*3220	2850	2140	*1590	*1590	6.86
1.5 m	kg			*6260	5830	*4150	3160	2760	2060	*1660	1610	7.03
0.0 m	kg			*7840	5460	4130	2990	2680	1990	*1840	1640	6.87
-1.5 m	kg	*4140	*4140	8040	5360	4040	2920	2650	1960	*2220	1820	6.35
-3.0 m	kg	*7290	*7290	*7460	5410	4070	2940			*3130	2310	5.38

4.30 m boom, 2.81 m arm equipped with 2450kg counter weight and 600mm triple grouser shoe with Dozer Down.









Lift-point height m	Lift-point radius								At max. Reach			
	1.5 m		3.0 m		4.5 m		6.0 m		Capacity		Reach m	
												
6.0 m	kg					*2480	*2480			*1770	*1770	5.34
4.5 m	kg					*2560	*2560	*2380	2360	*1610	*1610	6.33
3.0 m	kg			*3800	*3800	*3220	*3220	*2990	2310	*1590	*1590	6.86
1.5 m	kg			*6260	*6260	*4150	3420	*3390	2230	*1660	*1660	7.03
0.0 m	kg			*7840	6020	*4940	3260	*3750	2160	*1840	1780	6.87
-1.5 m	kg	*4140	*4140	*8160	5920	*5280	3180	*3840	2130	*2220	1970	6.35
-3.0 m	kg	*7290	*7290	*7460	5970	*4910	3200			*3130	2510	5.38

1. Lifting capacities are based on ISO 10567.
2. Lifting capacity of the HX A-series does not exceed 75% of tipping load with the machine on firm, level ground or 87% of full hydraulic capacity.
3. The Lift-point is bucket pivot mounting pin on the arm (without bucket mass).
4. (*) indicates load limited by hydraulic capacity.
5. Caution: please be aware of the local regulations and instructions for lifting operations.









 Rating over-front
  Rating over-side or 360 degrees

HX130A LCR 2-PIECE BOOM









4.56 m boom, 1.96 m arm equipped with 2450kg counter weight and 600mm triple grouser shoe without Dozer.

Lift-point height m	Lift-point radius						At max. Reach			
	3.0 m		4.5 m		6.0 m		Capacity		Reach	
									m	
6.0 m	kg			*3310	3280			*2670	*2670	4.66
4.5 m	kg	*3650	*3650	*3290	3260			*2360	2140	5.77
3.0 m	kg	*5580	*5580	*3900	3080	2850	1970	*2300	1790	6.34
1.5 m	kg			4270	2870	2770	1890	*2380	1660	6.53
0.0 m	kg	*4580	*4580	4120	2740	2700	1840	2500	1700	6.35
-1.5 m	kg	*7530	4990	4090	2710			2850	1930	5.79
-3.0 m	kg	*6230	5130	*4080	2800					

4.56 m boom, 1.96 m arm equipped with 2450kg counter weight and 600mm triple grouser shoe with Dozer Up.

Lift-point height m	Lift-point radius						At max. Reach			
	3.0 m		4.5 m		6.0 m		Capacity		Reach	
									m	
6.0 m	kg			*3310	*3310			*2670	*2670	4.66
4.5 m	kg	*3650	*3650	*3290	*3290			*2360	2270	5.77
3.0 m	kg	*5580	*5580	*3900	3270	2820	2100	*2300	1910	6.34
1.5 m	kg			4230	3050	2740	2020	*2380	1780	6.53
0.0 m	kg	*4590	*4590	4080	2920	2680	1960	2470	1820	6.35
-1.5 m	kg	*7520	5310	4050	2890			2820	2070	5.79
-3.0 m	kg	*6220	5460	*4080	2990					

4.56 m boom, 1.96 m arm equipped with 2450kg counter weight and 600mm triple grouser shoe with Dozer Down.

Lift-point height m	Lift-point radius						At max. Reach			
	3.0 m		4.5 m		6.0 m		Capacity		Reach	
									m	
6.0 m	kg			*3310	*3310			*2670	*2670	4.66
4.5 m	kg	*3650	*3650	*3290	*3290			*2360	*2360	5.77
3.0 m	kg	*5580	*5580	*3900	3540	*3360	2270	*2300	2070	6.34
1.5 m	kg			*4670	3320	*3630	2190	*2380	1930	6.53
0.0 m	kg	*4590	*4590	*5130	3190	*3810	2140	*2640	1980	6.35
-1.5 m	kg	*7520	5880	*5080	3160			*3220	2250	5.79
-3.0 m	kg	*6220	6030	*4080	3260					











1. Lifting capacities are based on ISO 10567.
2. Lifting capacity of the HX A-series does not exceed 75% of tipping load with the machine on firm, level ground or 87% of full hydraulic capacity.
3. The Lift-point is bucket pivot mounting pin on the arm (without bucket mass).
4. (*) indicates load limited by hydraulic capacity.
5. Caution: please be aware of the local regulations and instructions for lifting operations.

LIFTING CAPACITY











 Rating over-front  Rating over-side or 360 degrees

HX130A LCR 2-PIECE BOOM











4.56 m boom, 2.26 m arm equipped with 2450kg counter weight and 600mm triple grouser shoe without Dozer.

Lift-point height m		Lift-point radius								At max. Reach		
		1.5 m		3.0 m		4.5 m		6.0 m		Capacity		Reach m
												
7.5m	kg			*3450	*3450					*3330	*3330	3.04
6.0 m	kg					*2960	*2960			*2400	*2400	5.05
4.5 m	kg					*3050	*3050	*2580	2030	*2150	1970	6.09
3.0 m	kg			*5070	*5070	*3690	3120	2860	1980	*2100	1670	6.64
1.5 m	kg					4290	2890	2770	1900	*2170	1560	6.81
0.0 m	kg			*4920	*4920	4120	2730	2690	1830	2330	1580	6.65
-1.5 m	kg			*7690	4940	4060	2680	2680	1810	2620	1770	6.11
-3.0 m	kg			*6600	5060	4130	2740			3460	2340	5.09

4.56 m boom, 2.26 m arm equipped with 2450kg counter weight and 600mm triple grouser shoe with Dozer Up.

Lift-point height m		Lift-point radius								At max. Reach		
		1.5 m		3.0 m		4.5 m		6.0 m		Capacity		Reach m
												
7.5m	kg			*3460	*3460					*3330	*3330	3.05
6.0 m	kg					*2950	*2950			*2400	*2400	5.06
4.5 m	kg					*3050	*3050	*2590	2150	*2150	2090	6.09
3.0 m	kg			*5080	*5080	*3690	3300	2840	2110	*2100	1780	6.64
1.5 m	kg					4250	3070	2740	2020	*2170	1660	6.81
0.0 m	kg			*4930	*4930	4080	2910	2670	1950	2300	1690	6.65
-1.5 m	kg			*7690	5260	4020	2860	2660	1940	2590	1900	6.11
-3.0 m	kg			*6590	5380	4090	2930			3440	2500	5.09

4.56 m boom, 2.26 m arm equipped with 2450kg counter weight and 600mm triple grouser shoe with Dozer Down.

Lift-point height m		Lift-point radius								At max. Reach		
		1.5 m		3.0 m		4.5 m		6.0 m		Capacity		Reach m
												
7.5m	kg			*3460	*3460					*3330	*3330	3.05
6.0 m	kg					*2950	*2950			*2400	*2400	5.06
4.5 m	kg					*3050	*3050	*2590	2330	*2150	*2150	6.09
3.0 m	kg			*5080	*5080	*3690	3570	*3200	2280	*2100	1930	6.64
1.5 m	kg					*4500	3340	*3520	2200	*2170	1810	6.81
0.0 m	kg			*4930	*4930	*5050	3180	*3760	2120	*2390	1840	6.65
-1.5 m	kg			*7690	5830	*5110	3130	*3640	2110	*2870	2070	6.11
-3.0 m	kg			*6590	5950	*4410	3190			*3600	2720	5.09

1. Lifting capacities are based on ISO 10567.
2. Lifting capacity of the HX A-series does not exceed 75% of tipping load with the machine on firm, level ground or 87% of full hydraulic capacity.
3. The Lift-point is bucket pivot mounting pin on the arm (without bucket mass).
4. (*) indicates load limited by hydraulic capacity.
5. Caution: please be aware of the local regulations and instructions for lifting operations.

BUCKET SELECTION GUIDE & DIGGING FORCE

BUCKETS

All buckets are welded with high-strength steel.



SAE Heaped m ³	0.58	0.50	0.59	◆ 0.50	◆ 0.61
---------------------------	------	------	------	--------	--------

Capacity m ³		Width mm		Weight kg	Tooth EA	Recommendation mm							
						2100 kg CWT			2450 kg CWT				
SAE Heaped	CECE Heaped	Without Side Cutters	With Side Cutters			4300 Mono Boom			4300 Mono Boom			4560 2PC Boom	
						1960 Arm	2260 Arm	2810 Arm	1960 Arm	2260 Arm	2810 Arm	1960 Arm	2260 Arm
0.58	0.5	950	1110	438	5	●	○	■	●	○	○	○	○
0.5	0.44	900	960	425	4	●	●	○	●	●	●	●	●
0.59	0.52	1050	1110	473	5	●	○	■	●	○	■	○	■
◆ 0.50	0.46	762	788	422	4	●	●	○	●	●	●	●	●
◆ 0.61	0.56	914	940	474	5	○	■	■	●	○	■	○	■

◆ Hammerless tooth bucket

- Applicable for materials with density of 2100 kg/m³ or less
- Applicable for materials with density of 1800 kg/m³ or less
- Applicable for materials with density of 1500 kg/m³ or less
- ▲ Applicable for materials with density of 1200 kg/m³ or less
- X Not Recommended

ATTACHMENT

Booms and arms are welded with a low-stress, full-box section design.
4.3 m mono boom, 2-piece 4.56m boom and 1.96 m, 2.26m, 2.81 m arms are available.

DIGGING FORCE

Boom	Length	mm	4300 Mono Boom			4560 2PC Boom		Remark
			935			1410		
Arm	Length	mm	1960	2260	2810	1960	2260	
			573		601	664	573	
Bucket Digging Force	SAE	kN	83 [91]	84 [91]	84 [91]	83 [91]	84 [91]	[] : Power Boost
		kgf	8479 [9249]	8511 [9285]	8512 [9285]	8479 [9249]	8511 [9285]	
		ISO	kN	98 [107]	98 [107]	98 [107]	98 [107]	
kgf	9952 [10857]		9990 [10899]	9991 [10899]	9952 [10857]	9990 [10899]		
Arm Crowd Force	SAE		kN	59 [65]	55 [60]	48 [52]	59 [65]	
		kgf	6055 [6605]	5613 [6123]	4851 [5292]	6055 [6605]	5613 [6123]	
		ISO	kN	62 [68]	58 [63]	50 [54]	62 [68]	58 [63]
kgf	6364 [6943]		5877 [6411]	5044 [5503]	6364 [6943]	5877 [6411]		

Note: Boom weight includes arm cylinder, piping, and pin

Arm weight includes bucket cylinder, linkage, and pin

STANDARD/OPTIONAL EQUIPMENT

ENGINE	STD	OPT
Cummins F3.8		
Engine Auto Idle	•	
Engine Auto Shutdown Control	•	
Emergency Engine Stop Switch	•	
HYDRAULIC SYSTEM	STD	OPT
3-Power Mode, 2-Work Mode, User Mode	•	
Variable Power Control	•	
EPIC (Electric Pump Independent Control)	•	
Attachment Mode Flow Control	•	
Hyundai Bio Hydraulic oil (HBHO)		•
CAB & INTERIOR	STD	OPT
Rise-Up Type Windshield Wiper	•	
Radio / USB Player	•	
Handsfree Mobile Phone System with USB	•	
12V Power Outlet (24V DC to 12V DC converter)	•	
Electric Horn	•	
All-Weather Steel Cab with 360° Visibility	•	
Safety glass - Tempered glass	•	
Safety glass - Tempered glass with front laminated glass		•
Sliding Fold-In Front Window	•	
Sliding Side Window (LH)	•	
Lockable Door	•	
Storage Compartment	•	
Ashtray & Cigar Lighter		•
Transparent Cabin Roof-Cover	•	
Sun Visor	•	
Door And Cab Locks, One Key	•	
Mechanical Suspension Seat With Heater	•	
Pilot-Operated Slidable Joystick	•	
Console Box Height Adjust System	•	
Air Conditioner & Heater	•	
Defroster	•	
Starting Aid (Air Grid Heater) for Cold Weather	•	
8" LCD Display	•	
Engine Speed or Trip Meter / Accel.	•	
Engine Coolant Temperature Gauge	•	
Max Power	•	
Low Speed / High Speed	•	
Auto Idle	•	
Overload warning with alarm	•	
Check Engine	•	
Air Cleaner Clogging	•	
Indicators	•	
ECO Gauges	•	
Fuel Level Gauge	•	
Hyd. Oil Temperature Gauge	•	
Fuel Warmer	•	
Warnings	•	
Communication Error	•	
Low Battery	•	
Clock	•	
Cabin Lights	•	
Cabin Front Window Rain Guard	•	
Cabin Roof-Steel Cover		•
Adjustable Air Suspension Seat With Heater		•
FOG (Falling Object Protective Structure) - ISO 10262 Level		•
ROPS (Roll Over Protective Structures) ISO 12117-2	•	

SAFETY	STD	OPT
Lifting Mode	•	
Auto Safety Lock	•	
Seatbelt Warning Alarm	•	
Battery Master Switch	•	
Rear View Camera	•	
Rear & RH View Camera		•
AAVM (Advanced Around View Monitoring)		•
Four Front Working Lights (2 Boom Mounted, 2 Front Frame Mounted)	•	
Travel Alarm	•	
Beacon Lamp		•
Automatic Swing Brake	•	
Boom Holding System	•	
Arm Holding System	•	
Safety Lock Valve For Boom Cylinder With Overload Warning Device	•	
Safety Lock Valve For Arm Cylinder	•	
Safety Valve For Dozer Blade Cylinder	•	
Swing Lock System		•
Three Outside Rearview Mirror	•	
Guardrail - Boxing Ring		•

ATTACHMENT	STD	OPT
Booms		
4.3 m Mono	•	
4.56 m 2-Piece		•
Arms		
1.96 m		•
2.26 m	•	
2.81 m		•

OTHER	STD	OPT
Fuel Pre-Filter	•	
Fuel Warmer	•	
Pre-Cleaner		•
Coolant Heater		•
Self-Diagnostics System	•	
Hi MATE (Remote Management System)		•
Batteries (2 × 12 V × 100 AH)	•	
Fuel Filler Pump (20 lpm)		•
Single-Acting Piping Kit (Breaker, Etc.)		•
Double-Acting Piping Kit (Clamshell, Etc.)		•
Proportional Auxiliary Hydraulic System		•
2 Way Proportional RCV & Pedal Control Selection		•
Rotating Piping Kit		•
Bucket Line Dividing Kit		•
Air Compressor		•
Quick Coupler Piping		•
Quick Coupler		•
One Pedal Straight Travel System		•
Accumulator For Lowering Work Equipment	•	
Pattern Change Valve (2 Patterns)		•
Fine (Cushion/Free) Swing Control		•
Tool Kit		•
Dozer Blade		•

UNDERCARRIAGE	STD	OPT
Lower Frame Under Cover	•	
Track Shoes		
Triple Grousers Shoes (500 mm)		•
Triple Grousers Shoes (600 mm)	•	
Triple Grousers Shoes (600 mm) - HD Type		•
Triple Grousers Shoe (700 mm)		•
Triple Grousers Shoe (700 mm) - HD Type		•
Rubber Pad (500 mm)		•
Track Guard	•	

- * Standard and optional equipment may vary. Contact your Hyundai dealer for more information. The machine may vary according to International standards.
- * The photos may include attachments and optional equipment that are not available in your area.
- * Materials and specifications are subject to change without advance notice.

MEMO

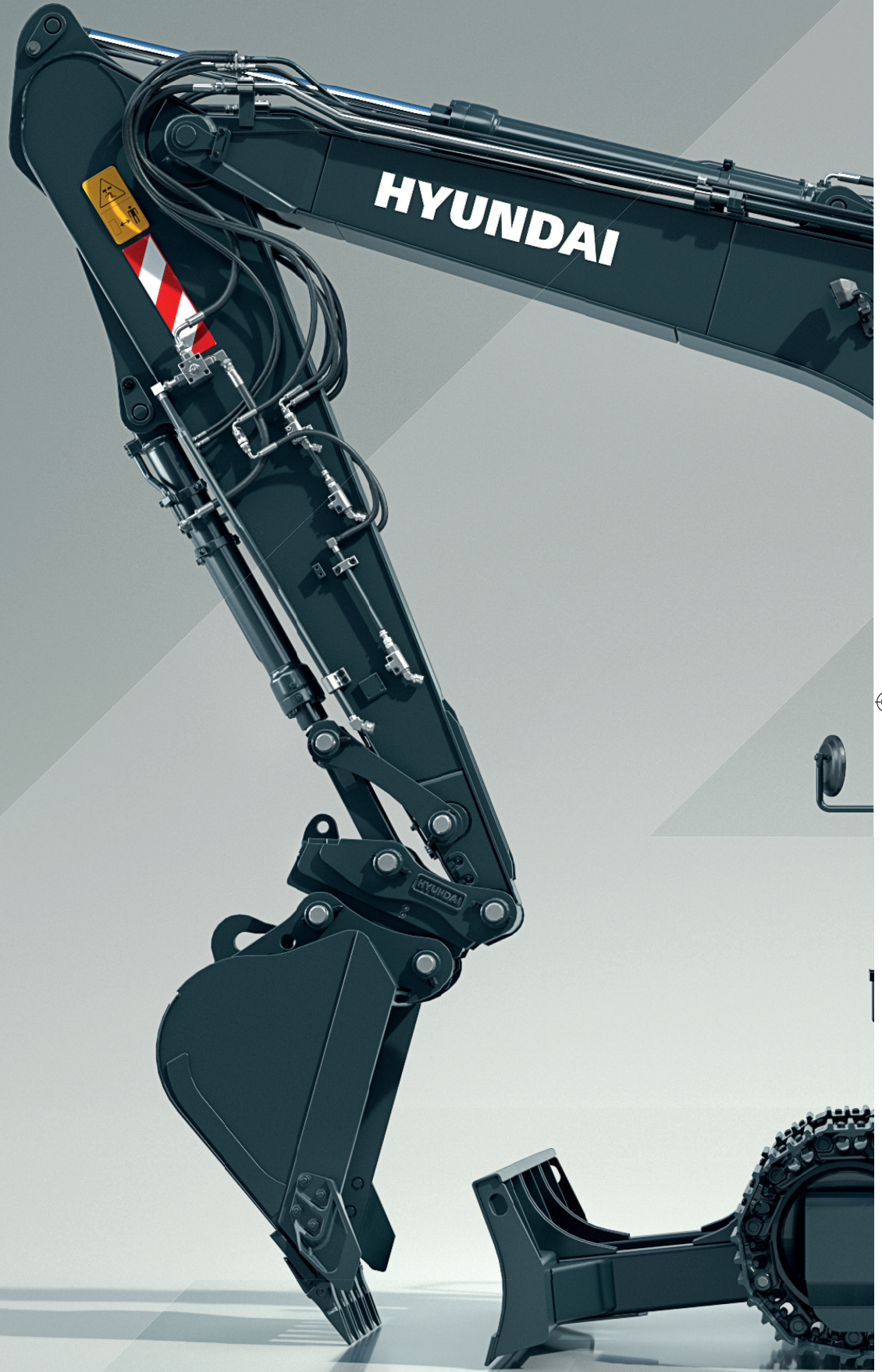

4

SERIES HX130ALCR





Specifications and design are subject to change without notice. Pictures of Hyundai Construction Equipment Europe products may show other than standard equipment.

Hyundai Construction Equipment Europe nv,
Hyundailaan 4, 3980 Tessenderlo, Belgium.
Tel: (32) 14-56-2200 Fax: (32) 14-59-3405

READY TO CHANGE YOUR WORLD?

Contact your Hyundai dealer.
hyundai-ce.eu/en/dealer-locator

 **HYUNDAI**
CONSTRUCTION EQUIPMENT

HY-CE-00010. 12/2021. EN. ISSUE 1